

PCI-1753/1753E

96/192-bit
Digital I/O Card

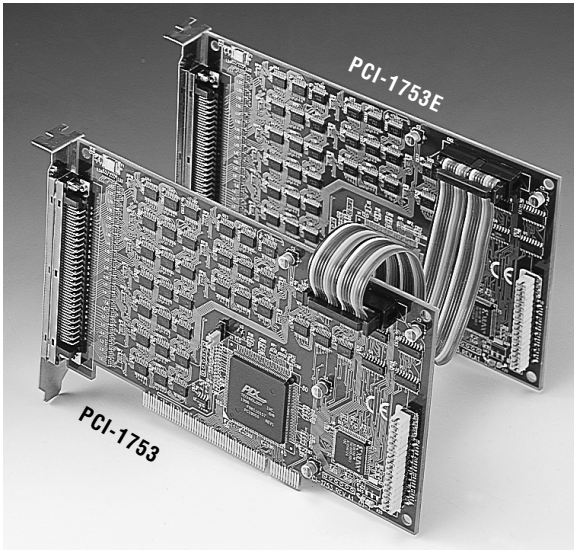

Features

- 96/192 TTL digital I/O lines
- Emulates mode 0 of 8255 PPI
- Buffered circuits for higher driving capacity than 8255
- Multiple-source interrupt handling
- Interrupt output pin for simultaneously triggering external devices with the interrupt
- Output status read-back
- “Pattern match” and “Change of state” interrupt functions for critical I/O monitoring
- Keeps I/O setting and digital output values when hot system reset
- Supports dry contact and wet contact
- High-density 100-pin SCSI connector

Introduction

The PCI-1753 is a 96-bit digital I/O card for the PCI bus, which can be extended to 192 digital I/O channels by connecting with its extension board, PCI-1753E. The card emulates mode 0 of the 8255 PPI chip, but the buffered circuits offer a higher driving capability than the 8255. The 96 I/O lines are divided into twelve 8-bit I/O ports: A0, B0, C0, A1, B1, C1, A2, B2, C2, A3, B3 and C3. Users can configure each port as input or output via software.

Easy to Install: Plug and Play

The PCI-1753 uses a PCI controller to interface the card to the PCI bus. The controller fully implements the PCI bus specification Rev 2.1. All bus relative configurations, such as base address and interrupt assignment, are automatically controlled by software.

Dry Contact Support for Digital Input

Each digital input channel of the PCI-1753/1753E accepts either 0 ~ 5 V_{DC} wet contact or dry contact inputs. This dry contact capability allows the channel to respond to changes in external circuitry (e.g., the closing of a switch in the external circuitry) when no voltage is present in the external circuit.

Reset Protection Fulfills the True Requirement of Industrial Applications

When the system is hot reset (the power is not turned off), the PCI-1753/1753E can either retain the value of the last I/O port settings and outputs, or return to its default configuration, depending on the jumper setting. This function protects the system from wrong operations during unexpected system resets.

Interrupt Functions Ensure Faster System Response

Two lines of each port C (i.e., ports C0, C1, C2 and C3) are connected to an interrupt circuit. The “Interrupt Control Register” of the

PCI-1753/PCI-1753E controls how these signals generate an interrupt. Two interrupt request signals can be generated at the same time, and then the software can process these two request signals by ISR. The dual interrupt sources provide the card with more capability and flexibility.

The PCI-1753/1753E also provides “Pattern Match” interrupt function for port A0. The card monitors the states of port A0 and compares them with a pre-set pattern. When the received state matches the pre-set pattern, the PCI-1753/1753E generates an interrupt signal to the system.

“Change of State” interrupt function is provided at port B0. When any signal line of port B0 changes its state, the card generates an interrupt to the system to handle this event.

These interrupt functions release the CPU from the burden of pulling all I/O points, enabling a PC to handle more I/O points with higher performance.

Cost Savings for Increasing the Number of Input/Output Lines

Industrial users are needing more and more digital I/O lines to transmit data or to monitor/control outside devices. To meet this trend and to satisfy user’s budget considerations, Advantech has developed an extension board for the PCI-1753 called the PCI-1753E. The PCI-1753E has almost the same structure as the PCI-1753, without the interface controller. It shares PCI-1753’s interface controller through a 10-cm flat cable connection, so users can spend less money while doubling the number of input/output lines.

Accessories for PCI-1753/1753E

The PCI-1753/1753E uses a 100-pin SCSI female connector. For easy signal wiring, a PCI-1753 can be connected to two ADAM-3968s by a 100-pin to 2x68-pin SCSI cable (part number PCL-10268). The ADAM-3968 allows easy access for wiring the individual pins of a 68-pin SCSI connector. An ADAM-3968/50 adapter board converts the 68-pin connector to two opto-22 compatible 50-pin box headers for connecting the PCI-1753/1753E to daughterboards, such as PCLD-782B and PCLD-785B.

Applications

- Industrial AC/DC I/O devices for monitoring and controlling
- Relay and switch monitoring and controlling
- Parallel data transfer
- TTL, DTL and CMOS logic signal sensing
- Indicator LED driving

Block Diagram

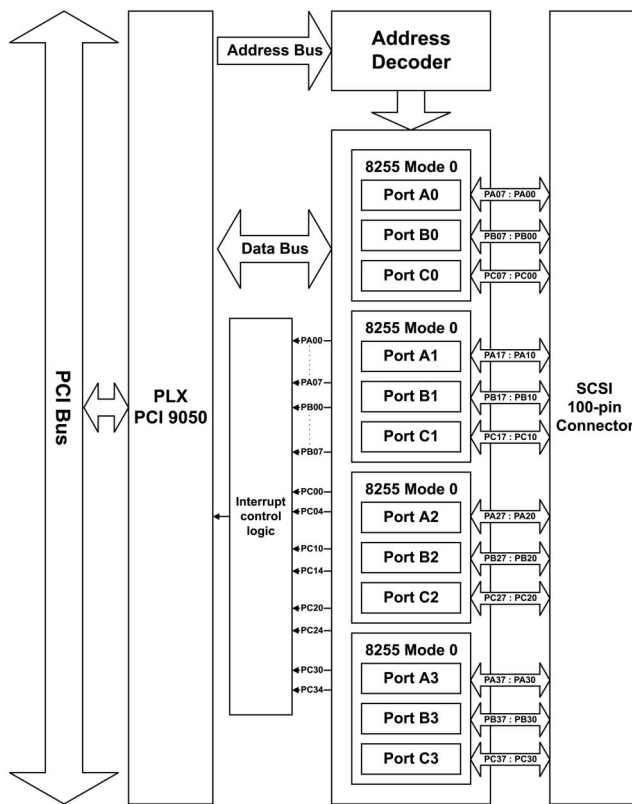

PCI-1753 block diagram

Specifications

- **I/O Channels:** 96 digital I/O lines for only PCI-1753;
192 digital I/O lines by extending to PCI-1753E
- **Programming Mode:** 8255 PPI mode 0
- **Input Signal:** logic level 0: 0.8 V max.
logic level 1: 2.0 V min.
- **Output Signal:** logic level 0: 0.44 V max. @ 24 mA (sink)
logic level 1: 3.76 V min. @ 24 mA (source)
- **Power Consumption:** +5 V @ 400 mA (typical)
+5 V @ 0.7 A (max.)
- **Operating Temperature:** 0° ~ 60° C (32° ~ 140° F)
(refer to IEC 68-2-1, 2)

- **Storage Temperature:** -20° ~ 70° C (-4° ~ 158° F)
(refer to IEC 68-2-3)
- **Operating Humidity:** 5% ~ 95%RH non-condensing
- **Connector:** one 100-pin SCSI female connector
- **Dimensions:** 175 mm (L) x 100 mm (H) (6.9" x 3.9")

Pin Assignments

PA00	1	51	PA20
PA01	2	52	PA21
PA02	3	53	PA22
PA03	4	54	PA23
PA04	5	55	PA24
PA05	6	56	PA25
PA06	7	57	PA26
PA07	8	58	PA27
PB00	9	59	PB20
PB01	10	60	PB21
PB02	11	61	PB22
PB03	12	62	PB23
PB04	13	63	PB24
PB05	14	64	PB25
PB06	15	65	PB26
PB07	16	66	PB27
PC00	17	67	PC20
PC01	18	68	PC21
PC02	19	69	PC22
PC03	20	70	PC23
PC04	21	71	PC24
PC05	22	72	PC25
PC06	23	73	PC26
PC07	24	74	PC27
GND	25	75	GND
PA10	26	76	PA30
PA11	27	77	PA31
PA12	28	78	PA32
PA13	29	79	PA33
PA14	30	80	PA34
PA15	31	81	PA35
PA16	32	82	PA36
PA17	33	83	PA37
PB10	34	84	PB30
PB11	35	85	PB31
PB12	36	86	PB32
PB13	37	87	PB33
PB14	38	88	PB34
PB15	39	89	PB35
PB16	40	90	PB36
PB17	41	91	PB37
PC10	42	92	PC30
PC11	43	93	PC31
PC12	44	94	PC32
PC13	45	95	PC33
PC14	46	96	PC34
PC15	47	97	PC35
PC16	48	98	PC36
PC17	49	99	PC37
VCC	50	100	VCC

PA00 ~PA07: I/O pins of Port A0
PA10 ~PA17: I/O pins of Port A1
PA20 ~PA27: I/O pins of Port A2
PA30 ~PA37: I/O pins of Port A3
PB00 ~PB07: I/O pins of Port B0
PB10 ~PB17: I/O pins of Port B1
PB20 ~PB27: I/O pins of Port B2
PB30 ~PB37: I/O pins of Port B3
PC00 ~PC07: I/O pins of Port C0
PC10 ~PC17: I/O pins of Port C1
PC20 ~PC27: I/O pins of Port C2
PC30 ~PC37: I/O pins of Port C3
GND: Ground
VCC: +5V voltage output

Ordering Information

- **PCI-1753:** 96/192-bit Digital I/O Card, user's manual and driver CD-ROM. (cable not included)
- **PCI-1753E:** Extension Board for PCI-1753
- **PCL-10268:** 100-pin to 2x68-pin SCSI cable, 1 and 2 m (PCL-10268 100-pin SCSI-II male connector P/N: 16549A0000)
- **ADAM-3968:** 68-pin SCSI wiring terminal for DIN-rail mounting
- **ADAM-3968/20:** 68-pin SCSI-II to Three 20-pin Wiring Terminal Module for DIN-Rail Mounting
- **ADAM-3968/50:** 68-pin SCSI wiring terminal for DIN-rail mounting